



High Performance Driver/Comparator Active Load on a Single Chip

AD53032

FEATURES

- 250 MHz Operation
- Driver/Comparator and Active Load Included
- On-Chip Schottky Diode Bridge
- 52-Lead LQFP Package with Built-in Heatsink

APPLICATIONS

- Automatic Test Equipment
- Semiconductor Test Systems
- Board Test Systems
- Instrumentation and Characterization Equipment

PRODUCT DESCRIPTION

The AD53032 is a single chip that performs the pin electronics functions of driver, comparator and active load in ATE VLSI and memory testers. In addition, a Schottky diode bridge for the active load and a VCOM buffer are included internally.

The driver is a proprietary design that features three active states: Data High Mode, Data Low Mode and Term Mode as well as an Inhibit State. This facilitates the implementation of high speed active termination. The output voltage range is -3 V to $+8\text{ V}$ to accommodate a wide variety of test devices. The output leakage is typically less than 250 nA over the entire signal range.

The dual comparator, with an input range equal to the driver output range, features built-in latches and ECL-compatible outputs. The outputs are capable of driving $50\ \Omega$ signal lines terminated to -2 V . Signal tracking capability is upwards of 5 V/ns .

The active load can be set for up to 35 mA load current with less than a $10\ \mu\text{A}$ linearity error through the entire set range. I_{OH} , I_{OL} and the buffered VCOM are independently adjustable. Onboard Schottky diodes provide high speed switching and low capacitance.

Also included on the chip is an onboard temperature sensor whose purpose is to give an indication of the surface temperature of the DCL. This information can be used to measure θ_{JC} and θ_{JA} or flag an alarm if proper cooling is lost. Output from the sensor is a current sink that is proportional to absolute temperature. The gain is trimmed to a nominal value of $1.0\ \mu\text{A/K}$. As an example, the output current can be sensed by using a $10\text{ k}\Omega$ resistor connected from $+10\text{ V}$ to the THERM (IOUT) pin. A voltage drop across the resistor will be developed that equals: $10\text{K} \times 1\ \mu\text{A/K} = 10\text{ mV/K} = 2.98\text{ V}$ at room temperature.

FUNCTIONAL BLOCK DIAGRAM

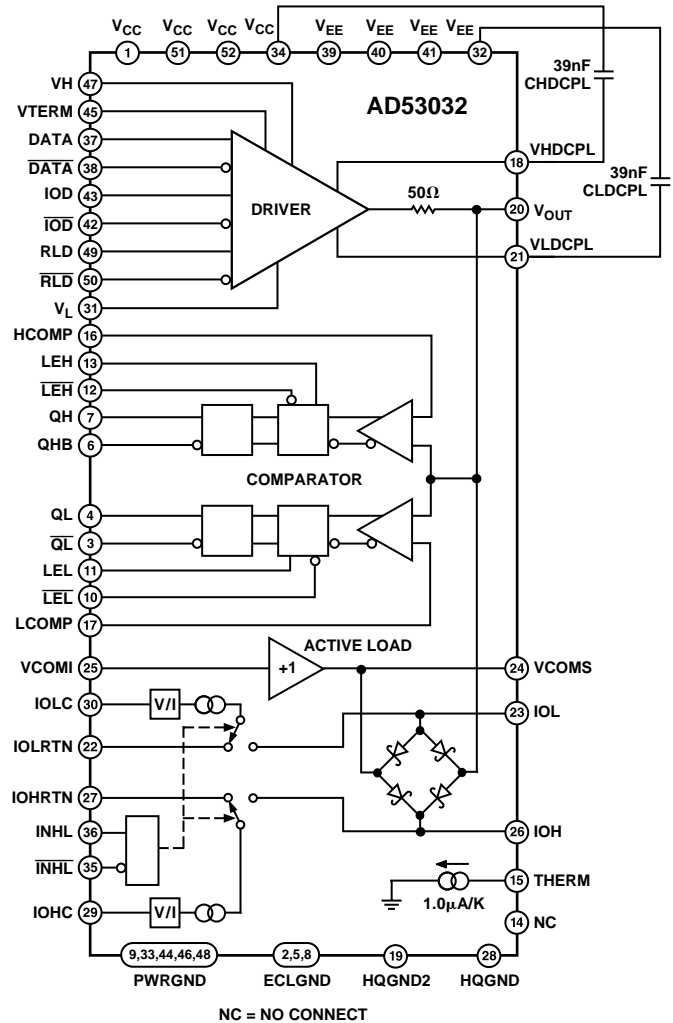

REV. 0

Information furnished by Analog Devices is believed to be accurate and reliable. However, no responsibility is assumed by Analog Devices for its use, nor for any infringements of patents or other rights of third parties which may result from its use. No license is granted by implication or otherwise under any patent or patent rights of Analog Devices.

AD53032—SPECIFICATIONS

DRIVER SPECIFICATIONS

(All specifications are at $T_J = +85^\circ\text{C} \pm 5^\circ\text{C}$, $+V_S = +12\text{ V} \pm 3\%$, $-V_S = -7\text{ V} = \pm 3\%$ unless otherwise noted. All temperature coefficients are measured at $T_J = +75^\circ\text{C}$ to $+95^\circ\text{C}$). CHDCPL = CLDCPL = 39 nF.

Parameter	Min	Typ	Max	Units	Test Conditions
DIFFERENTIAL INPUT CHARACTERISTICS (DATA to $\overline{\text{DATA}}$, IOD to $\overline{\text{IOD}}$, RLD to $\overline{\text{RLD}}$)					
Input Voltage	-2		0	V	
Differential Input Range		ECL			
Bias Current	-250		+250	μA	$V_{\text{IN}} = -2\text{ V}, 0.0\text{ V}$
REFERENCE INPUTS					
Bias Currents	-50		+50	μA	$V_L, V_H, V_T = 5\text{ V}$
OUTPUT CHARACTERISTICS					
Logic High Range	-2		8	V	DATA = H, $V_H = -2\text{ V}$ to $+8\text{ V}$ $V_L = -3\text{ V}$ ($V_H = -2\text{ V}$ to $+6\text{ V}$) $V_L = -1\text{ V}$ ($V_H = +6\text{ V}$ to $+8\text{ V}$)
Logic Low Range	-3		5	V	DATA = L, $V_L = -3\text{ V}$ to $+5\text{ V}$, $V_H = +6\text{ V}$
Amplitude (V_H and V_L)	0.1		9	V	$V_L = 0.0\text{ V}$, $V_H = +0.1\text{ V}$, $V_T = 0\text{ V}$
Absolute Accuracy					$V_L = -2\text{ V}$, $V_H = +7\text{ V}$, $V_T = 0\text{ V}$
V_H Offset	-50		+50	mV	DATA = H, $V_H = 0\text{ V}$, $V_L = -3\text{ V}$, $V_T = +3\text{ V}$
V_H Gain + Linearity Error	0.3 – 5		+0.3 + 5	% of V_H + mV	DATA = H, $V_H = -2\text{ V}$ to $+8\text{ V}$, $V_L = -3\text{ V}$, $V_T = +3\text{ V}$
V_L Offset	-50		+50	mV	DATA = L, $V_L = -3\text{ V}$, $V_H = +6\text{ V}$, $V_T = +7.5\text{ V}$
V_L Gain + Linearity Error	-0.3 – 5		+0.3 + 5	% of V_L + mV	DATA = L, $V_L = 0\text{ V}$, $V_H = +6\text{ V}$, $V_T = +7.5\text{ V}$
Offset TC		0.5		mV/ $^\circ\text{C}$	$V_L = 0\text{ V}$, $V_H = +5\text{ V}$, $V_T = 0\text{ V}$
Output Resistance					
$V_H = -2\text{ V}$	44	46	48	Ω	$V_L = -3\text{ V}$, $V_T = 0\text{ V}$, $I_{\text{OUT}} = 0, +1, +30\text{ mA}$
$V_H = +8\text{ V}$	44	46	48	Ω	$V_L = -1\text{ V}$, $V_T = 0\text{ V}$, $I_{\text{OUT}} = 0, -1, -30\text{ mA}$
$V_L = -3\text{ V}$	44	46	48	Ω	$V_H = +6\text{ V}$, $V_T = 0\text{ V}$, $I_{\text{OUT}} = 0, +1, +30\text{ mA}$
$V_L = +5\text{ V}$	44	46	48	Ω	$V_H = +6\text{ V}$, $V_T = 0\text{ V}$, $I_{\text{OUT}} = 0, -1, -30\text{ mA}$
$V_H = +3\text{ V}$		46		Ω	$V_L = 0\text{ V}$, $V_T = 0\text{ V}$, $I_{\text{OUT}} = -30\text{ mA}$ (Trim Point)
Dynamic Current Limit	100			mA	$C_{\text{BYP}} = 39\text{ nF}$, $V_H = +7\text{ V}$, $V_L = -2\text{ V}$, $V_T = 0\text{ V}$
Static Current Limit	-85		+85	mA	Output to -3 V , $V_H = +8\text{ V}$, $V_L = -1\text{ V}$, $V_T = 0\text{ V}$ DATA = H and Output to $+8\text{ V}$, $V_H = +6\text{ V}$, $V_L = -3\text{ V}$, $V_T = 0\text{ V}$, DATA = L
V_{TERM}					
Voltage Range	-3		8.0	V	TERM MODE, $V_T = -3\text{ V}$ to $+8\text{ V}$, $V_L = 0\text{ V}$, $V_H = 3\text{ V}$
V_{TERM} Offset	-50		+50	mV	TERM MODE, $V_T = 0\text{ V}$, $V_L = 0\text{ V}$, $V_H = 3\text{ V}$
V_{TERM} Gain + Linearity Error	-0.3 + 5		+0.3 + 5	% of V_{SET} + mV	TERM MODE, $V_T = -3\text{ V}$ to $+8\text{ V}$, $V_L = 0\text{ V}$, $V_H = 3\text{ V}$
Offset TC		0.5		mV/ $^\circ\text{C}$	$V_T = 0\text{ V}$, $V_L = 0\text{ V}$, $V_H = 3\text{ V}$
Output Resistance	44	46	49	Ω	$I_{\text{OUT}} = +30\text{ mA}, +1.0\text{ mA}$, $V_T = -3.0\text{ V}$, $V_H = 3\text{ V}$, $V_L = 0\text{ V}$ $I_{\text{OUT}} = -30\text{ mA}, -1.0\text{ mA}$, $V_T = +8.0\text{ V}$, $V_H = 3\text{ V}$, $V_L = 0\text{ V}$ $I_{\text{OUT}} = \pm 30\text{ mA}, \pm 1.0\text{ mA}$, $V_T = 0\text{ V}$, $V_H = 3\text{ V}$, $V_L = 0\text{ V}$
DYNAMIC PERFORMANCE, (V_H AND V_L)					
Propagation Delay Time	1.1	1.6	2.1	ns	Measured at 50%, $V_H = +400\text{ mV}$, $V_L = -400\text{ mV}$
Propagation Delay TC		2		ps/ $^\circ\text{C}$	Measured at 50%, $V_H = +400\text{ mV}$, $V_L = -400\text{ mV}$
Delay Matching, Edge to Edge		<100		ps	Measured at 50%, $V_H = +400\text{ mV}$, $V_L = -400\text{ mV}$
Rise and Fall Times					
1 V Swing		0.6		ns	Measured 20%–80%, $V_L = 0\text{ V}$, $V_H = 1\text{ V}$
3 V Swing		1.0		ns	Measured 20%–80%, $V_L = 0\text{ V}$, $V_H = 3\text{ V}$
5 V Swing		1.7		ns	Measured 10%–90%, $V_L = 0\text{ V}$, $V_H = 5\text{ V}$
9 V Swing		3.0		ns	Measured 10%–90%, $V_L = -2\text{ V}$, $V_H = 7\text{ V}$
Rise and Fall Time Temperature Coefficient					
1 V Swing		± 1		ps/ $^\circ\text{C}$	Measured 20%–80%, $V_L = 0\text{ V}$, $V_H = 1\text{ V}$
3 V Swing		± 2		ps/ $^\circ\text{C}$	Measured 20%–80%, $V_L = 0\text{ V}$, $V_H = 3\text{ V}$
5 V Swing		± 4		ps/ $^\circ\text{C}$	Measured 10%–90%, $V_L = 0\text{ V}$, $V_H = 5\text{ V}$
Overshoot and Preshoot	-3.0 – 50		+3.0 + 50	% of Step + mV	$V_L, V_H = -0.1\text{ V}, 0.1\text{ V}$, $V_L, V_H = 0.0\text{ V}, 1.0\text{ V}$ $V_L, V_H = 0.0\text{ V}, 3.0\text{ V}$, $V_L, V_H = 0.0\text{ V}, 5.0\text{ V}$ $V_L, V_H = -2.0\text{ V}, 7.0\text{ V}$
Settling Time					
to 15 mV		<50		ns	$V_L = 0\text{ V}$, $V_H = 0.5\text{ V}$
to 4 mV		<10		μs	$V_L = 0\text{ V}$, $V_H = 0.5\text{ V}$

Parameter	Min	Typ	Max	Units	Test Conditions
Delay Change vs. Pulsewidth		<50		ps	$V_L = 0\text{ V}, V_H = 2\text{ V}$
Minimum Pulsewidth					
3 V Swing		2		ns	$V_L = 0\text{ V}, V_H = 3\text{ V}, 90\% \text{ Reached, Measure @ } 50\%$
5 V Swing		3		ns	$V_L = 0\text{ V}, V_H = 5\text{ V}, 90\% \text{ Reached, Measure @ } 50\%$
Toggle Rate		250		MHz	$V_L = 0\text{ V}, V_H = 5\text{ V}, VDUT > 3.0\text{ V p-p}$
DYNAMIC PERFORMANCE, INHIBIT					
Delay Time, Active to Inhibit	1.5		4.0	ns	Measured at 50%, $V_H = +2\text{ V}, V_L = -2\text{ V}$
Delay Time, Inhibit to Active	1.5		3.5	ns	Measured at 50%, $V_H = +2\text{ V}, V_L = -2\text{ V}$
			± 1.0	ns	
Delay Time Matching (Z)			2.2	ns	Z = Delay Time Active to Inhibit Test (Above)— Delay Time Inhibit to Active Test (Above) (Of Worst Two Edges)
I/O Spike		<200		mV, p-p	$V_H = 0\text{ V}, V_L = 0\text{ V}$
Rise, Fall Time, Active to Inhibit			3.5	ns	$V_H = +2\text{ V}, V_L = -2\text{ V}$ (Measured 20%/80% of 1 V Output)
Rise, Fall Time, Inhibit to Active			2.2	ns	$V_H = +2\text{ V}, V_L = -2\text{ V}$ (Measured 20%/80% of 1 V Output)
DYNAMIC PERFORMANCE, V_{TERM}					
Delay Time, V_H to V_{TERM}			3.0	ns	Measured at 50%, $V_L = V_H = +0.4\text{ V}, V_{TERM} = -0.4\text{ V}$
Delay Time, V_L to V_{TERM}			5.0	ns	Measured at 50%, $V_L = V_H = +0.4\text{ V}, V_{TERM} = -0.4\text{ V}$
Delay Time, V_{TERM} to V_H and V_{TERM} to V_L			4.0	ns	Measured at 50%, $V_L = V_H = +0.4\text{ V}, V_{TERM} = -0.4\text{ V}$
Overshoot and Preshoot	$-3.0 + 75$		$+3.0 + 75$	% of Step + mV	$V_H/V_L, V_{TERM} = (+0.4\text{ V}, -0.4\text{ V}), (0.0\text{ V}, -2.0\text{ V}), (0.0\text{ V}, +7.0\text{ V})$
V_{TERM} Mode Rise Time			4.0	ns	$V_L, V_H = 0\text{ V}, V_{TERM} = -2\text{ V}, 20\% - 80\%$
V_{TERM} Mode Fall Time			5.5	ns	$V_L, V_H = 0\text{ V}, V_{TERM} = -2\text{ V}, 20\% - 80\%$
PSRR, DRIVE or TERM Mode	35			dB	$V_S = V_S \pm 3\%$

Specifications subject to change without notice.

COMPARATOR SPECIFICATIONS

(All specifications are at $T_j = +85^\circ\text{C} \pm 5^\circ\text{C}$, $+V_S = +12\text{ V} \pm 3\%$, $-V_S = -7\text{ V} = \pm 3\%$ unless otherwise noted. All temperature coefficients are measured at $T_j = +75^\circ\text{C}$ to $+95^\circ\text{C}$).

Parameter	Min	Typ	Max	Units	Test Conditions
DC INPUT CHARACTERISTICS					
Offset Voltage (V_{OS})	-25		25	mV	$CMV = 0\text{ V}$
Offset Voltage (Drift)		50		$\mu\text{V}/^\circ\text{C}$	$CMV = 0\text{ V}$
HCOMP, LCOMP Bias Current	-50		50	μA	$V_{IN} = 0\text{ V}$
Voltage Range (V_{CM})	-3		8.0	V	
Differential Voltage (V_{DIFF})			9.0	V	
Gain and Linearity	-0.05		0.05	% FSR	$V_{IN} = -3\text{ V}$ to $+8\text{ V}$
LATCH ENABLE INPUTS					
Logic "1" Current (I_{IH})			250	μA	$LE, \overline{LE} = -0.8\text{ V}$
Logic "0" Current (I_{IL})	-250			μA	$LE, \overline{LE} = -1.8\text{ V}$
DIGITAL OUTPUTS					
Logic "1" Voltage (V_{OH})	-0.98			V	Q or \overline{Q} , 50 Ω to -2 V
Logic "0" Voltage (V_{OL})			-1.5	V	Q or \overline{Q} , 50 Ω to -2 V
Slew Rate		1		V/ns	
SWITCHING PERFORMANCE					
Propagation Delay					
Input to Output	0.9		2.5	ns	$V_{IN} = 2\text{ V p-p}$,
Latch Enable to Output		2		ns	HCOMP = $+1\text{ V}$, LCOMP = $+1\text{ V}$
Propagation Delay Temperature Coefficient		2		$\text{ps}/^\circ\text{C}$	
Propagation Delay Change with Respect to					
Slew Rate: 0.5 V, 1.0 V, 3.0 V/ns		< ± 100		ps	$V_{IN} = 0\text{ V}$ to 5 V
Slew Rate: 5.0 V/ns		< ± 350		ps	$V_{IN} = 0\text{ V}$ to 5 V
Amplitude: 1.0 V, 3.0 V, 5.0 V		< ± 200		ps	$V_{IN} = 1.0\text{ V/ns}$
Equivalent Input Rise Time		450		ps	$V_{IN} = 0\text{ V}$ to $3\text{ V}, 3\text{ V/ns}$
Pulsewidth Linearity		< ± 200		ps	$V_{IN} = 0\text{ V}$ to $3\text{ V}, 3\text{ V/ns}, PW = 3\text{ ns} - 8\text{ ns}$
Settling Time		<25		ns	Settling to $\pm 8\text{ mV}, V_{IN} = 1\text{ V}$ to 0 V
Latch Timing					
Input Pulsewidth		<1.5		ns	
Setup Time		<1.0		ns	
Hold Time		<1.0		ns	

Specifications subject to change without notice.

AD53032—SPECIFICATIONS

ACTIVE LOAD SPECIFICATIONS

(All specifications are at $T_J = +85^\circ\text{C} \pm 5^\circ\text{C}$, $+V_S = +12\text{ V} \pm 3\%$, $-V_S = -7\text{ V} = \pm 3\%$ unless otherwise noted. All temperature coefficients are measured at $T_J = +75^\circ\text{C}$ to $+95^\circ\text{C}$).

Parameter	Min	Typ	Max	Units	Test Conditions
INPUT CHARACTERISTICS					
INH, $\overline{\text{INH}}\text{L}$					
Input Voltage	-2		0	V	IOHC = +1 V, IOLC = +1 V, VCOM = +2 V, VDUT = 0 V
Bias Current	-250		250	μA	INH, $\overline{\text{INH}}\text{L} = -2\text{ V}, 0\text{ V}$
IOHC Current Program Range					
IOH = 0 mA to -35 mA	0		3.5	V	VDUT = -1.7 V, +8 V
IOLC Current Program Range					
IOL = 0 mA to +35 mA	0		3.5	V	VDUT = -3 V, +6.7 V
IOHC, IOLC Input Bias Current	-300		300	μA	IOLC = 0 V, +3.5 V and IOHC = 0 V, +3.5 V
IOLRTN, IOHRTN Range	-3		8	V	IOL = +35 mA, IOH = -35 mA, VDUT = -3 V, +8 V
VDUT Range	-3		8	V	IOL = +35 mA, IOH = -35 mA, IVDUT-VCOMI > 1.3 V
VDUT Range, IOH = 0 mA to -35 mA	-1.7		8	V	VDUT - VCOM > 1.3 V
VDUT Range, IOL = 0 mA to +35 mA	-3		8	V	VCOM - VDUT > 1.3 V
VCOMI Input Range	-3		8	V	IOL = +35 mA, IOH = -35 mA
OUTPUT CHARACTERISTICS					
Accuracy					
Absolute Accuracy Error, Load Current	-0.4 - 200		+0.4 + 200	% $I_{\text{SET}} + \mu\text{A}$	IOL, IOH = 25 μA -35 mA, VCOM = 0 V, VDUT = $\pm 2\text{ V}$ and IOL = 25 μA -35 mA, VCOM = +8 V, VDUT = +6.7 V and IOH = 25 μA -35 mA, VCOM = -3 V, VDUT = -1.7 V
VCOM Buffer					
Offset Error	-50		50	mV	IOL, IOH = 35 mA, VCOMI = 0 V
Bias Current	-10	1	10	μA	VCOMI = 0 V
Gain Error	-0.2		0.2	%	IOL, IOH = 35 mA, VCOMI = -2 V to +7 V
Linearity Error	-10		10	mV	IOL, IOH = 35 mA, VCOMI = -2 V to +7 V
Output Current TC		< ± 2		$\mu\text{A}/^\circ\text{C}$	Measured at IOH, IOL = 200 μA
DYNAMIC PERFORMANCE					
Propagation Delay					
$\pm\text{IMAX}$ to Inhibit	0.8	1.5	2.5	ns	VCOM = $\pm 3\text{ V}$, IOL = +20 mA, IOH = -20 mA
Inhibit to $\pm\text{IMAX}$	1.5	2.4	4.0	ns	VCOM = $\pm 3\text{ V}$, IOL = +20 mA, IOH = 20 mA
Propagation Delay Matching	-1.8		1.8	ns	
I/O Spike		<250		mV	VCOM = 0 V, IOL = +20 mA, IOH = -20 mA
Settling Time to 15 mV		<50		ns	IOL = +20 mA, IOH = -20 mA, 50 Ω Load, to 15 mV
Settling Time to 4 mV		<10		μs	IOL = +20 mA, IOH = -20 mA, 50 Ω Load, to 4 mV

Specifications subject to change without notice.

TOTAL FUNCTION SPECIFICATIONS

(All specifications are at $T_J = +85^\circ\text{C} \pm 5^\circ\text{C}$, $+V_S = +12\text{ V} \pm 3\%$, $-V_S = -7\text{ V} = \pm 3\%$ unless otherwise noted. All temperature coefficients are measured at $T_J = +75^\circ\text{C}$ to $+95^\circ\text{C}$).

Parameter	Min	Typ	Max	Units	Test Conditions
OUTPUT CHARACTERISTICS					
Output Leakage Current, $V_{\text{OUT}} = -2\text{ V}$ to $+7\text{ V}$	-500		+500	nA	
Output Leakage Current, $V_{\text{OUT}} = -3\text{ V}$ to $+8\text{ V}$	-2		+2	μA	
Output Capacitance		8		pF	Driver and Load INHIBITED
POWER SUPPLIES					
Total Supply Range		19		V	
Positive Supply		12		V	
Negative Supply		-7		V	
Positive Supply Current			260	mA	Driver = I_{NH} , I_{LOAD} Program = 35 mA, Load = Active
Negative Supply Current			270	mA	Driver = I_{NH} , I_{LOAD} Program = 35 mA, Load = Active
Total Power Dissipation			5.0	W	Driver = I_{NH} , I_{LOAD} Program = 35 mA, Load = Active
Temperature Sensor Gain Factor		1		$\mu\text{A}/\text{K}$	$R_{\text{LOAD}} = 10\text{ k}\Omega$, $V_{\text{SOURCE}} = +10\text{ V}$

NOTES

Connecting or shorting the decoupling pins to ground will result in the destruction of the device.

Specifications subject to change without notice.

Table I. Driver Truth Table

DATA	$\overline{\text{DATA}}$	IOD	$\overline{\text{IOD}}$	RLD	$\overline{\text{RLD}}$	OUTPUT STATE
0	1	1	0	X	X	VL
1	0	1	0	X	X	VH
X	X	0	1	0	1	INH
X	X	0	1	1	0	VTERM

Table II. Comparator Truth Table

VOUT		LEH	$\overline{\text{LEH}}$	LEL	$\overline{\text{LEL}}$	OUTPUT STATES			
						QH	$\overline{\text{QH}}$	QL	$\overline{\text{QL}}$
>HCOMP	>LCOMP	1	0	1	0	1	0	1	0
>HCOMP	<LCOMP	1	0	1	0	1	0	0	1
<HCOMP	>LCOMP	1	0	1	0	0	1	1	0
<HCOMP	<LCOMP	1	0	1	0	0	1	0	1
X	X	0	1	0	1	QH (t-1)	$\overline{\text{QH}}$ (t-1)	QL (t-1)	$\overline{\text{QL}}$ (t-1)

Table III. Active Load Truth Table

VDUT	INHL	$\overline{\text{INHL}}$	OUTPUT STATES (Including Diode Bridge)		
			IOH	IOL	I(VOUT)
<VCOM	0	1	$V(\text{IOHC}) \times 10 \text{ mA}$	$V(\text{IOLC}) \times 10 \text{ mA}$	IOL
>VCOM	0	1	$V(\text{IOHC}) \times 10 \text{ mA}$	$V(\text{IOLC}) \times 10 \text{ mA}$	IOH
X	1	0	0	0	0

AD53032

ABSOLUTE MAXIMUM RATINGS¹

Power Supply Voltage

+V _S to GND	+13 V
-V _S to GND	-8 V
+V _S to -V _S	+20 V
PWR GND to ECL GND or HQ GND	±0.4 V

Inputs

DATA, $\overline{\text{DATA}}$, IOD, $\overline{\text{IOD}}$, RLD, $\overline{\text{RLD}}$	+5 V, -3 V
DATA to $\overline{\text{DATA}}$, IOD to $\overline{\text{IOD}}$, RLD to $\overline{\text{RLD}}$	±3 V
L $\overline{\text{EL}}$, $\overline{\text{LEL}}$, L $\overline{\text{EH}}$, $\overline{\text{LEH}}$	+5 V, -3 V
L $\overline{\text{EL}}$ to $\overline{\text{LEL}}$, L $\overline{\text{EH}}$ to $\overline{\text{LEH}}$	±3 V
INHL, $\overline{\text{INHL}}$	+5 V, -3 V
INHL to $\overline{\text{INHL}}$	±3 V
VH, VL, VTERM, VCOM_I to GND	+9 V, -4 V
VH to VL	±11 V
(VH-VTERM) and (VTERM-VL)	±11 V
IOHC	±6 V
IOLC	±6 V
HCOMP	+9 V, -4 V
LCOMP	+9 V, -4 V
HCOMP, LCOMP to V _{OUT}	±11 V

Outputs

V _{OUT} Short Circuit Duration	Indefinite ²
V _{OUT} Inhibit Mode	+9 V, -4 V
VHDCPL	Do Not Connect Except for Cap to V _{CC}
VLDCPL	Do Not Connect Except for Cap to V _{EE}
QH, $\overline{\text{QH}}$, QL, $\overline{\text{QL}}$ Maximum I _{OUT}	
Continuous	50 mA
Surge	100 mA
THERM	+13 V, 0 V
IOHRTN, IOLRTN	+8.5 V, -3.5 V
VCOM_S Short Circuit Duration	3 sec ²

Environmental

Operating Temperature (Junction)	+175°C
Storage Temperature	-65°C to +150°C
Lead Temperature (Soldering, 10 sec) ³	+260°C

NOTES

¹Stresses above those listed under Absolute Maximum Ratings may cause permanent damage to the device. This is a stress rating only; functional operation of the device at these or any other conditions above those indicated in the operational sections of this specification is not implied. Absolute maximum limits apply individually, not in combination. Exposure to absolute maximum rating conditions for extended periods may affect device reliability.

²Output short circuit protection is guaranteed as long as proper heatsinking is employed to ensure compliance with the operating temperature limits.

³To ensure lead coplanarity (±0.002 inches) and solderability, handling with bare hands should be avoided and the device should be stored in environments at 24°C ±5°C (75°F ± 10°F) with relative humidity not to exceed 65%.

Table IV. Package Thermal Characteristics

Air Flow, FM	θ _{JA} , °C/W
0	33
200	25
400	22

ORDERING GUIDE

Model	Package Description	Shipment Method Quantity per Shipping Container	Package Option
AD53032JSTP	52-Lead LQFP-EDQUAD	90	SQ-52

CAUTION

ESD (electrostatic discharge) sensitive device. Electrostatic charges as high as 4000 V readily accumulate on the human body and test equipment and can discharge without detection. Although the AD53032 features proprietary ESD protection circuitry, permanent damage may occur on devices subjected to high energy electrostatic discharges. Therefore, proper ESD precautions are recommended to avoid performance degradation or loss of functionality.



PIN CONFIGURATION

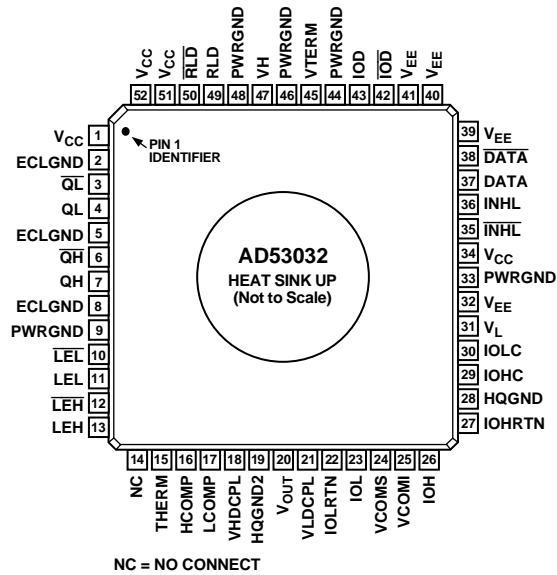

OUTLINE DIMENSIONS

Dimensions shown in inches and (mm).

**52-Lead LQFP-EDQUAD with Integral Heat Slug
(SQ-52)**

